

# FDZ CONNECTOR

**ZIF**  
TYPE

*Connectors for FPC and membrane switch leads*

**The FDZ connector, a Zero Insertion Force (ZIF) connector, was developed to connect FPC and membrane switch leads. This combination of features allows greater freedom in internal wiring designs. No force is required to insert the leads. Once inserted, the leads are securely held and locked by moving the slide. The contact is double-sided to ensure greater reliability.**

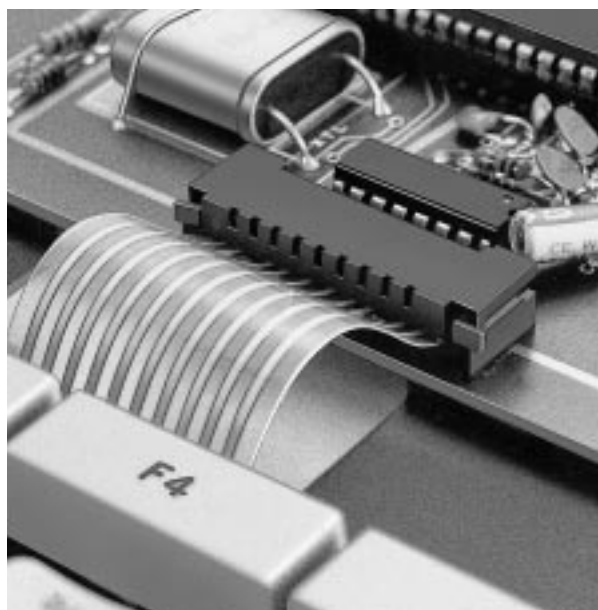
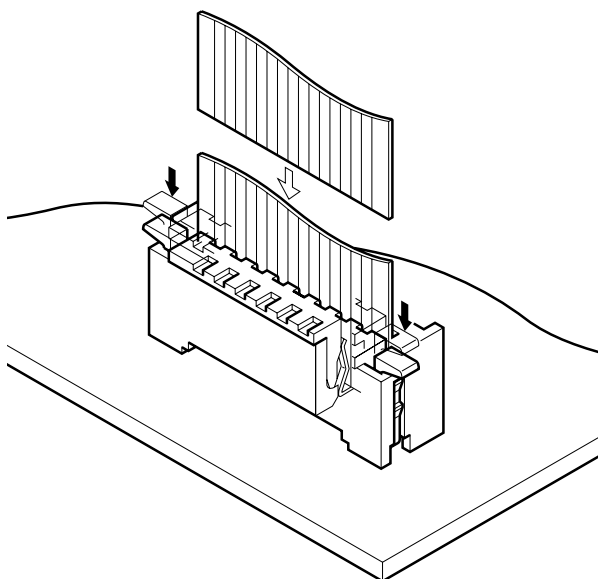

## Features

### • Double-sided contact

The contact is double-sided, thus providing redundant and highly reliable contact with FPC and membrane switch leads. This allows greater freedom in specifying the membrane switch lead conducting surfaces for use in keyboards.

### • Zero insertion force and locking mechanism

A ZIF mechanism increases wear resistance and extends the connector's mating life. The leads are securely connected by simply moving the slide. This greatly reduces the damage to the conducting surfaces of the leads. This mechanism is therefore ideal for silver-paste carbon-printed pattern leads which are susceptible to wear. The slide also has a hook to ensure secure contact and a tight hold.

### • Temporary board retention feature

The contact solder tail has a board retention feature that allows the connector to be temporarily held on the printed circuit board while it is being soldered. As a result, the connector can be located accurately in the finished product.

### • Boss for polarity identification

A boss (projection) on the bottom of the housing prevents improper insertion in the printed circuit board and provides greater mounting stability.

### • Flux is not a problem

The bottom of the connector housing is raised 2.0mm (.079") from the surface of the printed circuit board. This prevents flux being trapped under the connector. In addition, the central section of the contact has a special form that prevents flux from rising into the connector due to capillary action.

**Caution:** Flux level should be lower than the printed circuit board.

## Specifications

- Current rating: Tin-plated copper foil lead/1.0A AC, DC  
Silver paste carbon-painted lead/50mA AC, DC
- Voltage rating: 250V AC, DC
- Temperature range: -40°C to +85°C  
(including temperature rise in applying electrical current)
- Contact resistance: Tin-plated copper foil lead  
Initial value/30mΩ max.  
After environmental testing/40mΩ max.  
Silver paste carbon-printed lead  
Initial value/10Ω max.  
After environmental testing/15Ω max.
- Insulation resistance: 1,000MΩ min.
- Withstanding voltage: 1,200V AC/minute
- Applicable FPC and membrane switch lead:  
<Note> Lead pitch/2.54mm(.100")  
Lead width/1.3mm(.051")  
Mating part thickness/0.05 to 0.20mm  
(.002" to .008")
- Applicable PC board thickness: 1.6mm(.063")  
<Note>These are reference values. FFC/FPC to be actually used should be checked for applicability.

\* Contact JST for details.

## Standards

Recognized file No. E60389

Certified file No. LR20812

# FDZ CONNECTOR

## Connector

Top entry type (Before slide lock)

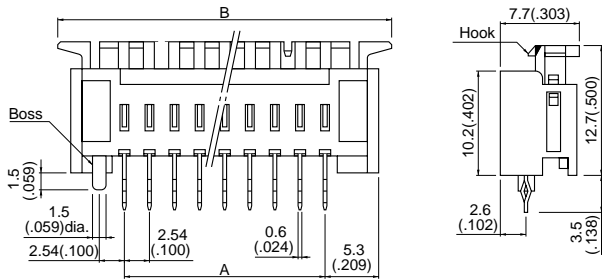

Side entry type (After slide lock)

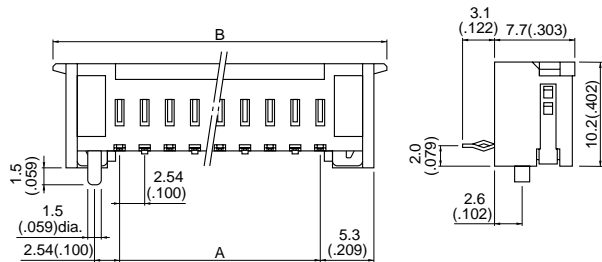

Circuits	Model No.		Dimensions mm(in.)		Q'ty / box
	Top entry type	Side entry type	A	B	
5	05FDZ-BT	05FDZ-ST	10.16( .400)	23.56( .928)	100
6	06FDZ-BT	06FDZ-ST	12.70( .500)	26.10(1.028)	100
8	08FDZ-BT	08FDZ-ST	17.78( .700)	31.18(1.228)	100
9	09FDZ-BT	09FDZ-ST	20.32( .800)	33.72(1.328)	100
10	10FDZ-BT	10FDZ-ST	22.86( .900)	36.26(1.428)	100
11	11FDZ-BT	11FDZ-ST	25.40(1.000)	38.80(1.528)	50
12	12FDZ-BT	12FDZ-ST	27.94(1.100)	41.34(1.628)	50
13	13FDZ-BT	13FDZ-ST	30.48(1.200)	43.88(1.728)	50
17	17FDZ-BT	17FDZ-ST	40.64(1.600)	54.04(2.128)	50

**Material and Finish**

Contact: Phosphor bronze, tin-plated  
Housing: Glass-filled PBT, UL94V-0, black

## Lead section dimensions of FPC

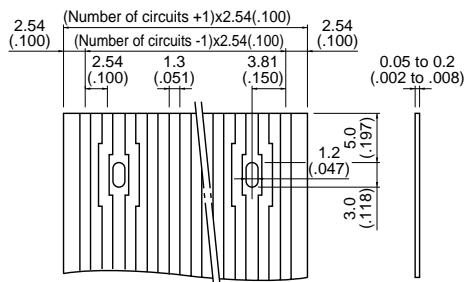

## FDZ CONNECTOR

## PC board layout (viewed from soldering side) and Assembly layout

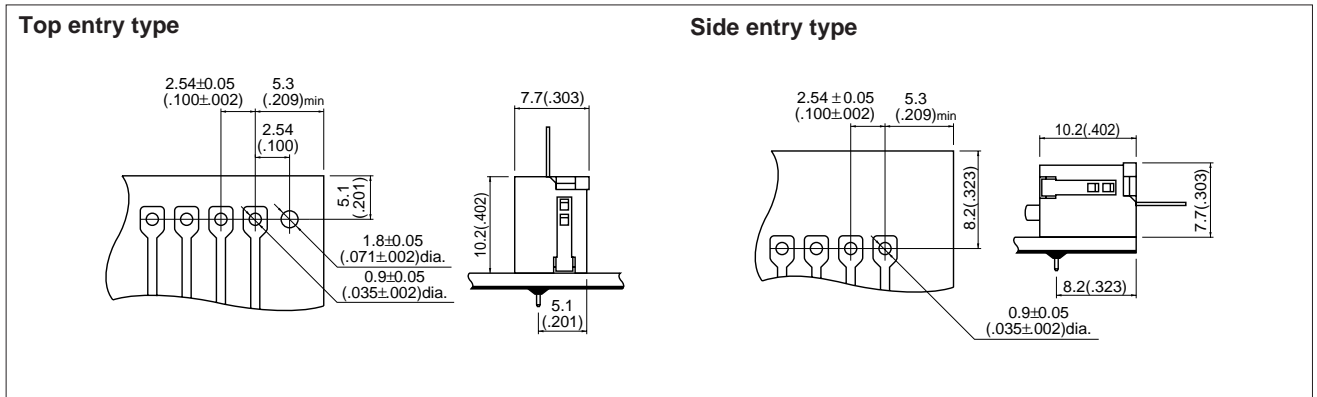

## Note:

1. Tolerances are non-cumulative:  $\pm 0.05$  mm ( $\pm .002$ " ) for all centers.
2. Hole dimensions differ according to the kind of PC board and piercing method. The dimensions above should serve as a guideline. Contact JST for details.